

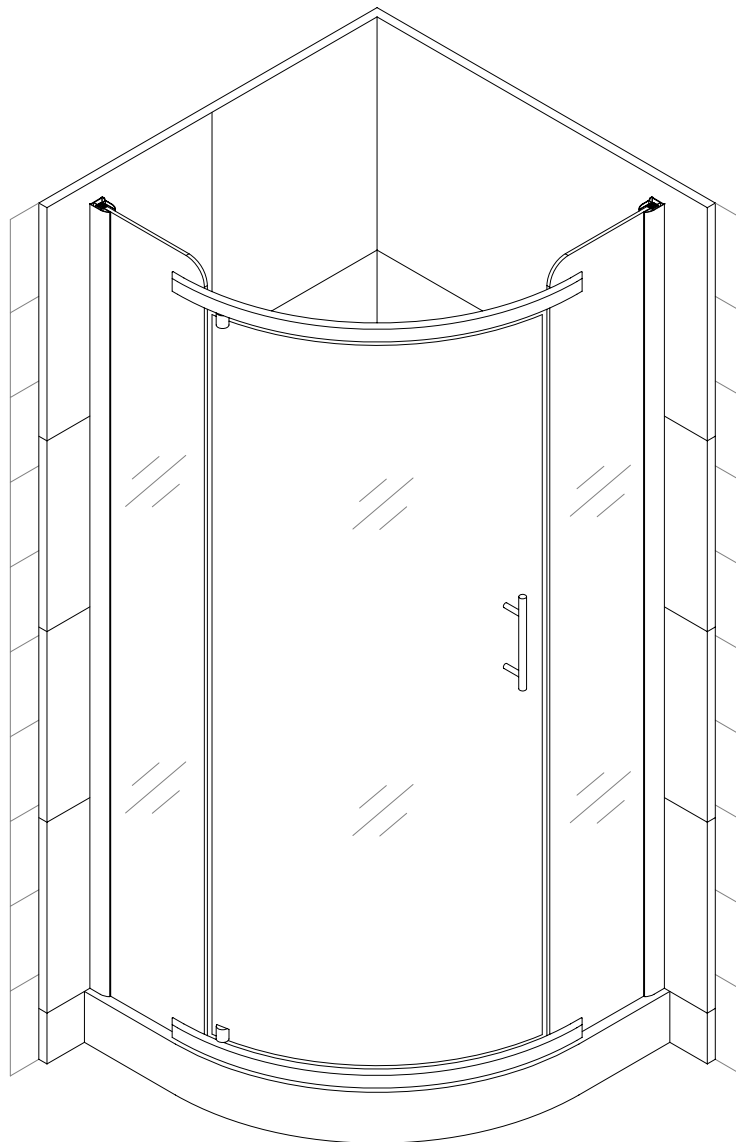

## CRESCENT Shower Enclosure Installation Instructions

### **IMPORTANT**

Please read carefully the following instructions before installing your shower enclosure. If you have any questions on this shower enclosure installation - please call our technical support specialists Monday to Friday 9:00AM – 5:00PM EST at 1-866-731-8378 Option 3 or e-mail our technical support group at [\*\*support@BathAuthority.com\*\*](mailto:support@BathAuthority.com)



**Our product may have changes without prior notice**

## Preparation

1. After opening all the boxes, read this introduction carefully, check all the packed parts are complete by cross checking all the components against the “Detailed Diagram of Shower Enclosure Components”. Examine for shipping damage. If the unit has been damaged or has a finishing defect, please contact your local distributor within 3 business days. Please note that **Bath Authority™ / DreamLine™ will not replace any damaged product or parts free of charge after 3 business days or if the product has been installed.** Contact your distributor or distributor if you have any questions.
2. **Please note that you should consult your local building codes on questions on installation compliance standards. Building and plumbing codes vary by location, and DreamLine is not responsible for code compliance standards for your project.**
3. Install all of the required plumbing and drainage before securing the shower. **Use a competent and licensed (if required by local code) plumber for all plumbing installation.**
1. Please insure that prior to the installation the floor is leveled and solid and will be able to support the total weight of the unit and its occupant. Also make sure the walls are at right angles. Irregular floor level or improper angle of side walls will result in serious problems for your installation. Please, note that there are some adjustments and drilling might be necessary during the installation process.

## Tools Required

Electric drill, Masonry drill bit (D=6mm not provided), Pencil, Phillips screwdriver, Slotted screwdriver, Tape measure, Spirit level with horizontal and vertical indicators.

Note: If glass has silk, print or molded designs, please put clear side toward inside.

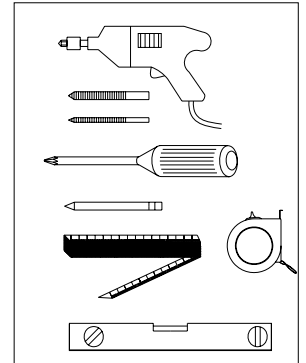

## Detailed Diagram of Shower Cabin Components

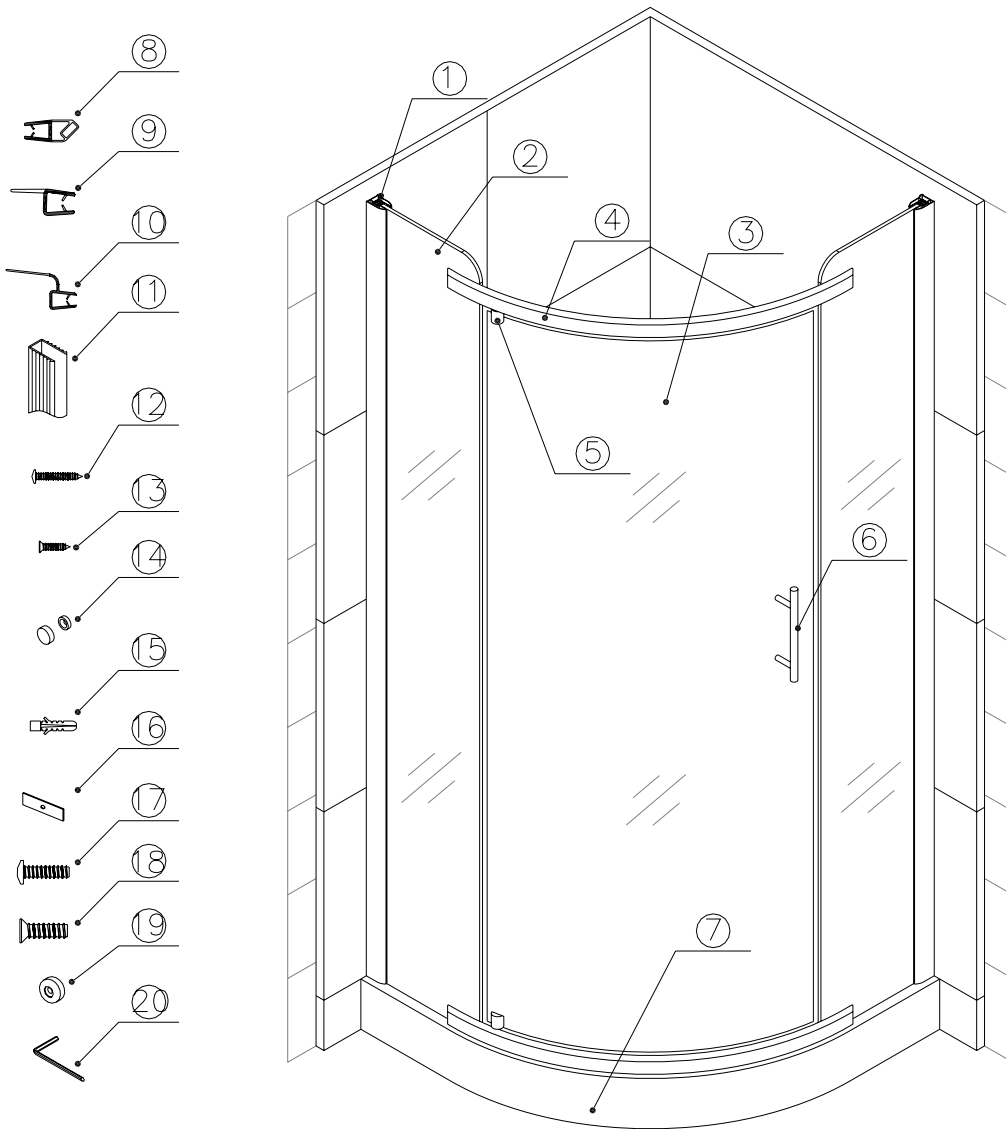

### Packing List

01	Glass and wall profile	2 pcs	11	U-shape seal gasket	1 pc
02	Stationary glass	2 pcs	12	Round head self-tapping screw ST4.2×30	8 pcs
03	Pivot swing door	1 pc	13	Flat head self tapping screw ST4.2×15	8 pcs
04	Top & bottom pivot bars	2 pcs	14	Decorative screw cover set	8 pcs
05	Pivot assembly	2 pcs	15	Wall Anchor	8 pcs
06	Door handle	1 pc	16	Gasket	4 pcs
07	Bottom tray (optional)	1 pc	17	M8x12 Round head bolt	4 pcs
08	Magnetic door strip	2 pcs	18	M8x20 Flat head bolt	4 pcs
09	Bottom door anti-water strip	1 pc	19	Decorative glass holder	4 pcs
10	Flanged anti-water strip	1 pc	20	Allen Key	1 pc

**Now that you have checked that all listed components are there, you are now ready to start the installation of your Dreamline shower enclosure.**

## Assembly steps

Install a shower tray according to the Tray installation manual. You should do it before the wonder board and finish wall installation.

The shower enclosure has to be installed after you finish the wall.

1. Start installation from either wall. Locate the **L-shape wall profile (1)** from the package then place it vertically above the tray 34 5/8" or 38 5/8" (refer to Diagram 1) from the corner to the external edge of the profile depending on the model. Using a level, adjust the L-shaped profile upright, then, use predrilled into aluminum profile holes to put on marks for drilling. Now drill the holes and insert the **wall anchors (15)** into the hole. Using **4X30 round head self-tapping screw (12)** to attach the Wall profile to the wall (fig 1).  
**Be sure that profile is absolutely vertical.**
2. Have out one of the **Stationary Glass panels (2)**. Locate small holes on the stationary glass. These holes must face towards the door. Place a **U-Shape Seal Gasket (11)** on the long (vertical) side of the glass panel; fit the glass with the gasket into the position (fig 2).
3. Attach the second part of **wall profile (1)** to the **L-shape profile** using **4X16 flat head self-tapping screw (13)** and fasten tight the profile so to secure the position of the stationary glass. Cover the holes with **Decorative cover (14)** (fig 2).
4. Repeat step 1-3 to install another side wall profile and second stationary Glass Panel. Check, if the stationary glass panels installed vertical in both directions (fig 3).
5. Locate the **Pivot Bar (4)**, then, locate the parts **(16, 18, 19)** to fasten the pivot bar to the stationary panels. Use the clear rubber **gasket (16)** to prevent from glass to metal connection. Secure the stationary glass panels with the **decorative glass holders (19)** using the **M8x20 Flat head bolts (18)** (Fig 4).
6. Locate two **pivot assemblies (5)**. Fasten them to the pivot bar using **M8x12 Round head bolts (17)** (Fig 5).
7. Remove the back fastener from the pivot assemblies. Set the door so the holes are aligned. Make sure the rubber gaskets are in between the glass and the metal parts. Secure the back fastener with the provided bolt (Fig 6).
8. Repeat the same steps for the second pivot assembly (Fig 7).
9. Install the **Handle (6)** to the **Glass door**. Don't forget to use the rubber gaskets between the glass and washers. Push on the **Magnetic strips (8)** on the glass door and the stationary panel, the **bottom door anti-water strip (9)** and the **Flanged anti-water strip (10)** to seal between the glass door and the other stationary glass panel (Fig 8).
10. Apply silicone sealant along the wall profiles and along the bottom of the stationary panels as well as along the pivot bar.

Diagram 1

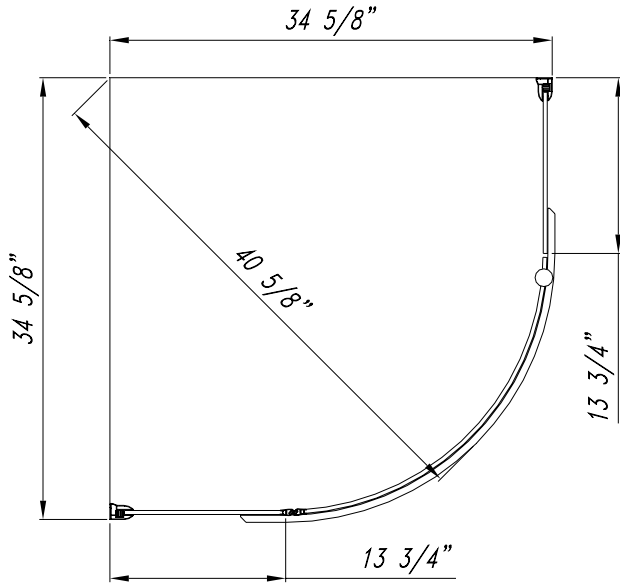

SHEN-7135356

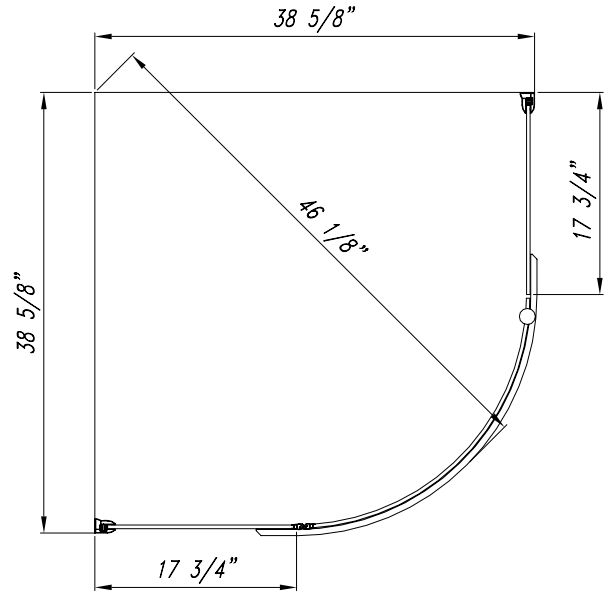

SHEN-7139396

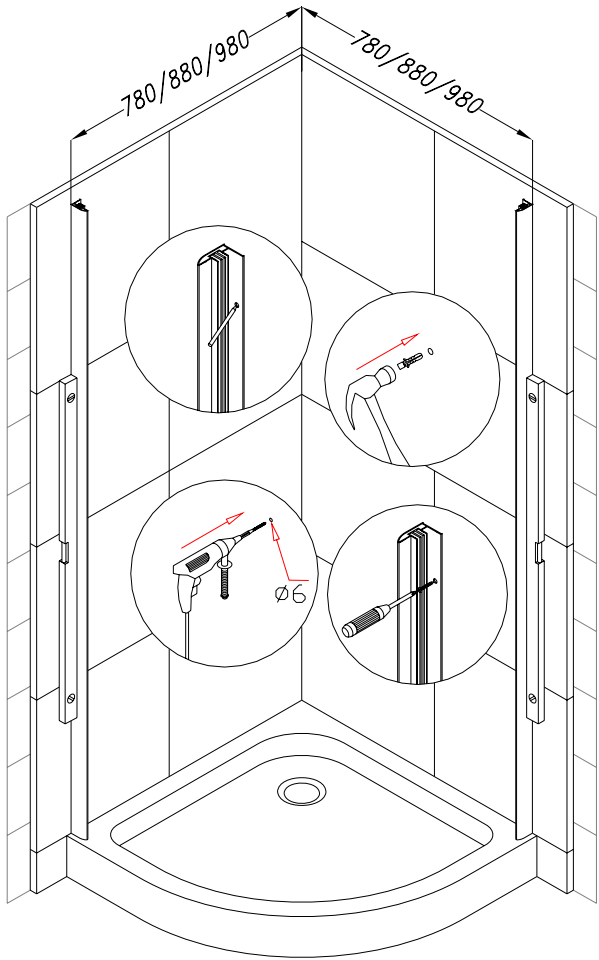

Fig 1

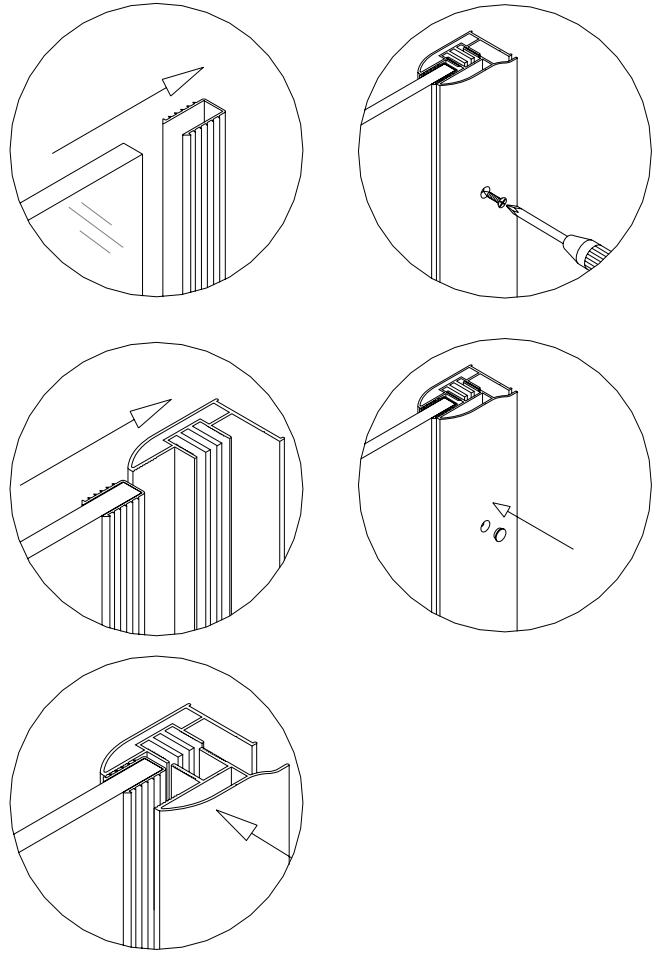

Fig 2

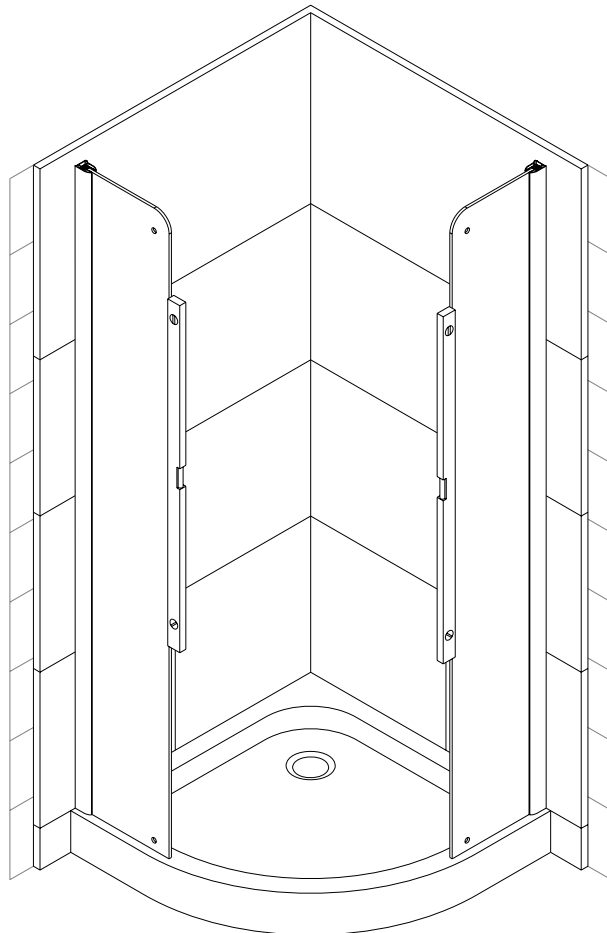

Fig 3

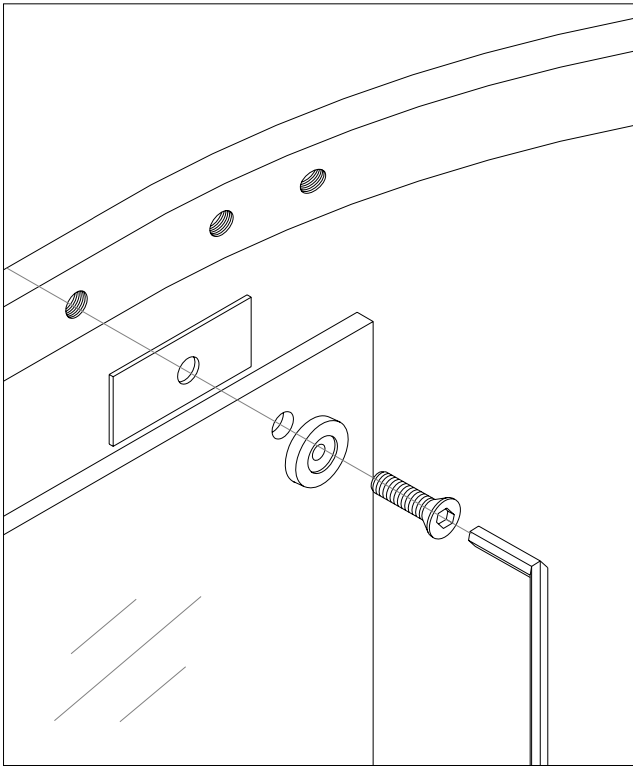

Fig 4

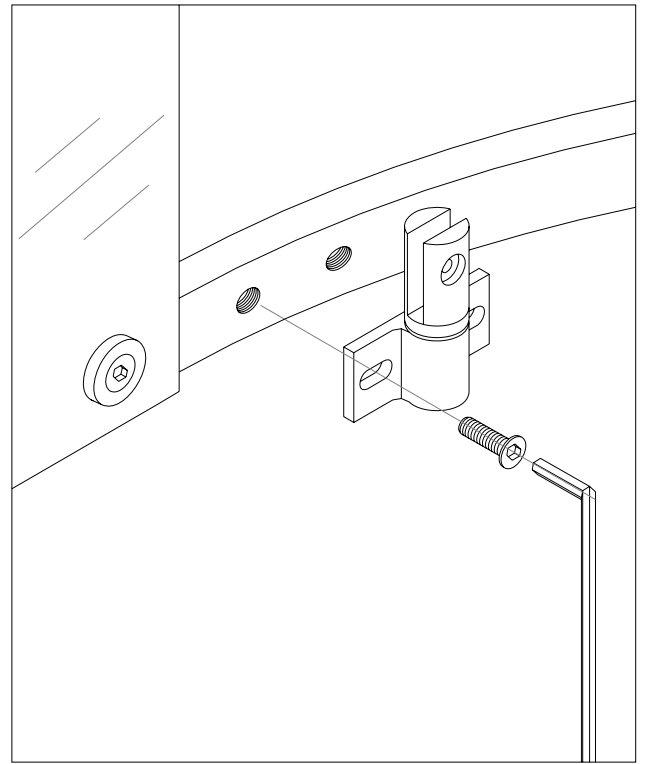

Fig 5

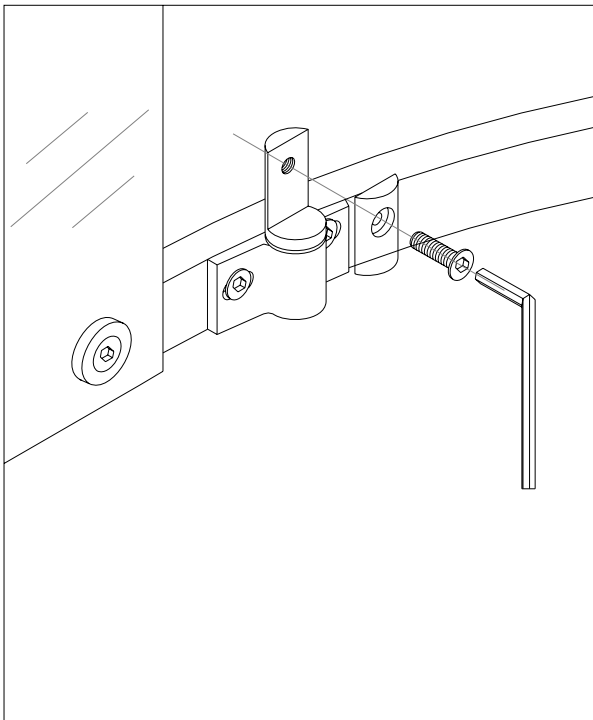
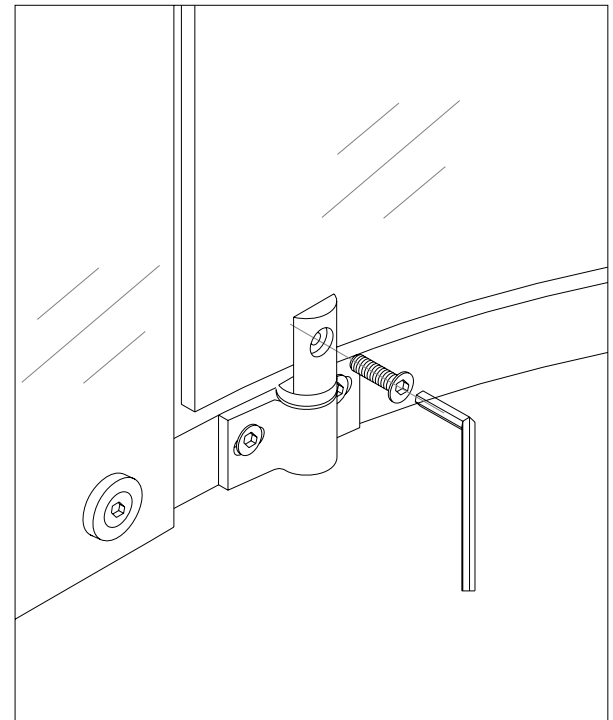

Fig 6



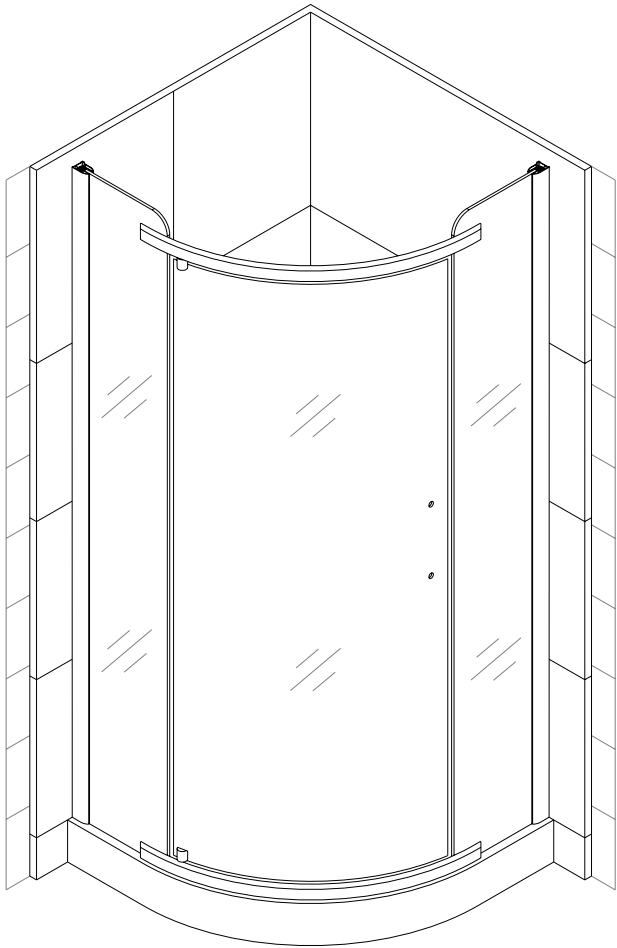

Fig 7

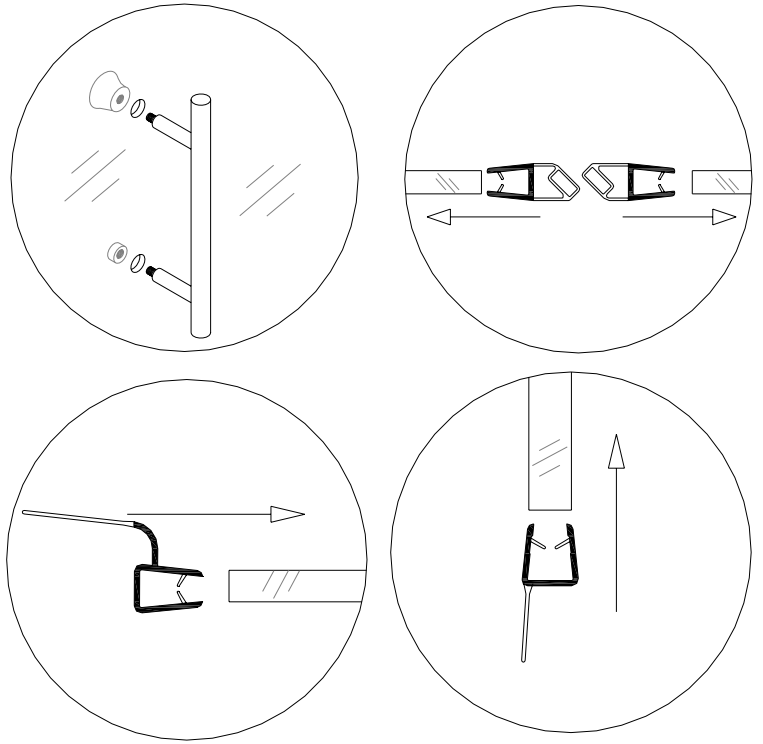

Fig 8

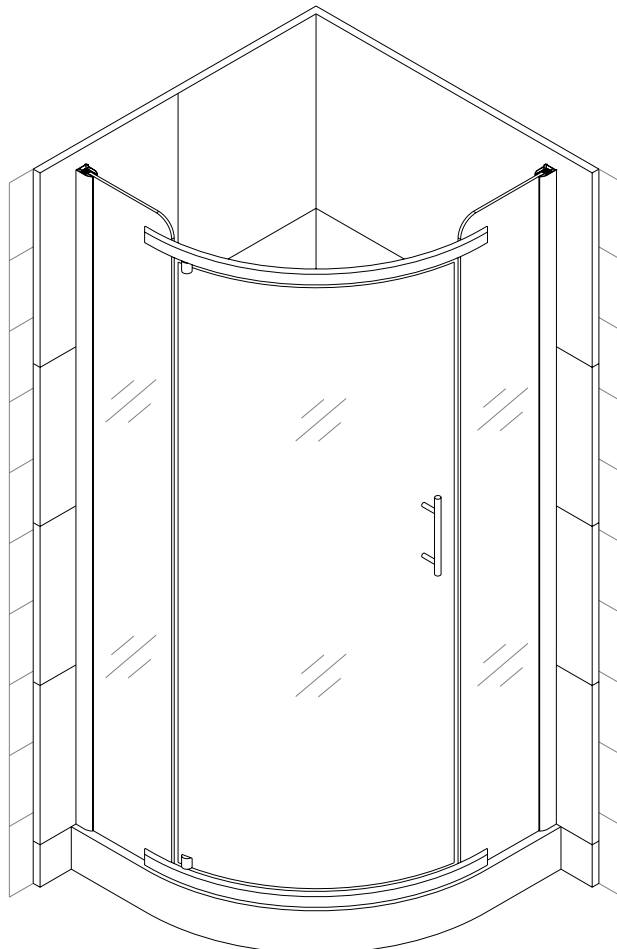

Fig 9



## **Product Maintenance**

1. Tempered glass can be clean with nonabrasive bathroom cleaner or any glass cleaner you use elsewhere in your home. Rinse off any glass cleaner that gets on the aluminum as soon as possible to avoid damage to the anodized surface. Avoid striking it with any sharp or hard objects. Such damage can cause either immediate or delayed breakage of tempered glass.

2. The aluminum in your shower door is durable and resistant to water damage. It is advisable, but not necessary to wipe it with your towel after your shower. Clean it as often as needed to keep the buildup off. Never use any type of abrasive cleaner. Use only a soft damp cloth and nonabrasive bathroom cleaners.

**Our product may have changes without prior notice**

# Bath Authority™ LLC / DreamLine™ Shower Enclosure, Jetted/Steam Shower and Shower Columns Limited Warranty

## CONSUMER RESPONSIBILITIES

Your DreamLine™ Shower Products will remain beautiful for many years if you take care of them. Some of the waterproofing plastic strips and other seals will need to be replaced when they show signs of wear, yellowing, or are not watertight. Refer to the parts list of your manual for all seals. Water conditions in various parts of the country will determine any extra cleaning attention you may have to give your new shower enclosure or jetted shower. DreamLine™ does not recommend the use of harsh abrasive cleansers on any of its products. Harsh cleansers will damage the metal or glass finish on your shower enclosure or jetted shower.

## REQUESTING SERVICE

Here's what you need to do if you require service:

1. Contact the dealer who sold and/or installed the product. They should be able to solve any problems you may have.
2. If your dealer or contractor cannot solve the problem, they will contact or supply you with the name of the local DreamLine™ Distributor or a DreamLine™ Direct Technical Specialist
3. If you are unable to obtain warranty service through either your contractor or DreamLine™ distributor, please write us directly at

Bath Authority™ LLC / DreamLine™  
909 Louis Drive  
Warminster, PA 18974  
ATTN: Customer Service Department

4. Include all pertinent information regarding your claim, including a complete description of the product, model numbers, colors, finishes, and the date the product was installed. Include a description of the problem and a photocopy of your invoice and purchase receipt(s) for the products involved. Also please provide information on the name and contact telephone numbers of the contractor and distributor.

Please note that under any circumstances, DreamLine™ products should not be returned to your dealer, distributor or directly to DreamLine™ without a written Return Merchandise Authorization (RMA).

## LIMITED ONE-YEAR WARRANTY

This warrantee extends only to the original owner/end-user for personal household use only. For commercial uses, additional limitations may apply.

DreamLine™ warrants acrylic surface against blistering or cracking and chipping resulting from defect in the acrylic surface material when used under normal condition and service for a period of one (1) year from the purchase date.

DreamLine™ warrants mirrors, shower doors, shower massage systems, faucet finishes and fittings to be free from defects in workmanship and materials under normal use and service for a period of one (1) year.

DreamLine™ further warrants the structure of the acrylic shell against loss of water through the fiberglass laminate of the acrylic body as a result of defect in materials and workmanship for a period of five (5) years from the purchase date.

DreamLine™ will, at its election, repair, replace, or make appropriate credit adjustment where DreamLine™ optional inspection discloses any such defects occurring in normal usage within the warrantee periods.

**Please note that DreamLine™ is not responsible for any installation or removal costs.**

Improper modification of any enclosure, jetted shower or shower column components may void the warrantee - so please install the product as directed in the manual. This warrantee does not cover any claim arising from abuse, misuse, negligence, accident, improper installation or operations on the part of the purchaser. This warrantee is void if the DreamLine™ product is subject to alterations, or if repairs are attempted by anyone other than an authorized agent of DreamLine™. This warrantee does not extend to any plumbing or components installed by dealers, installers or by any party other than DreamLine™.

**Implied warranties, including that of merchantability or fitness for a particular purpose, are expressly limited in duration to the duration of this warranty. DreamLine™ disclaims any liability for special, incidental, or consequential damages.**

Some states do not allow limitations on how long an implied warranty lasts or the exclusion or limitation of special, incidental, or consequential damages, so these limitations and exclusions may not apply to you. This warranty gives you specific legal rights. You may also have other rights which vary from state to state. This limited warranty provides specific legal rights as they apply within the USA, and other rights may be available, but may vary from country to country.

***This is our exclusive written warranty for DreamLine™ Shower Enclosure, Jetted/Steam Shower and Shower Column purchases made after May 2004. DreamLine™ reserves the right to modify this warranty at any time, and the consumer understands that such modification will not alter the warranty conditions applicable at the time of the sale of the product.***